



**NJPA AWARDED CONTRACT**

# Loadmaster



- 12 mph max speed
- 110 in turning radius
- 1,600 lb load capacity

## ***TOUGH & DEPENDABLE BURDEN CARRIER***



Taylor-Dunn's Loadmaster is durable, reliable and cost effective for your commercial and industrial material handling needs. Equipped with a 36-volt electric drive train, this vehicle carries loads up to 1,600 pounds at speeds up to 12 miles per hour with a range up to 20 miles.

This narrow aisle burden carrier is 44.5 inches wide by 108 inches long. It has a 110 inch turning radius with an 84 inch intersecting aisle clearance.

Adding optional equipment such as ladder rack, stake sides, tool boxes, tool cabinets or work bench makes this an excellent choice for any indoor or outdoor maintenance application.

Visit our website for images, videos, information, and custom modification ideas at [taylor-dunn.com](http://taylor-dunn.com).

<b>VOLTAGE</b>	36 volt	
<b>SPEED</b>	12 mph	19.3 km
<b>RANGE</b>	20 mi	32 km
<b>LOAD</b>	1600 lb	726 kg
<b>BED SIZE</b>	44x63 in	112x160 cm
<b>TURNING RADIUS</b>	110 in	279 cm

**\* Based on Standard Configuration**

Actual towing capacity is dependent on application, vehicle configuration, ballast weight, operating environment, and vehicle maintenance.

**Note:** Photos are shown with optional features.

### **FEATURES & BENEFITS:**

- Driver seat interlock safety feature
- Fully welded unitized steel body
- Front & rear spring suspension
- Customizable to fit your application

# B-150

## PERFORMANCE

<b>LOAD CAPACITY</b>	1600 lb	726 kg
<b>TOW CAPACITY</b>	7500 lb	3409 kg
<b>MAX SPEED (UNLOADED)</b>	12 mph	19 km/h
<b>TURNING RADIUS</b>	110 in	279 cm

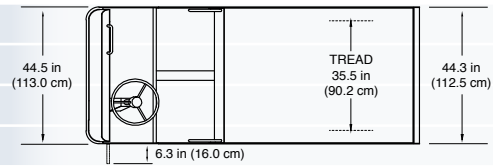

## DIMENSIONS

<b>OVERALL LENGTH</b>	108 in	274 cm
<b>OVERALL WIDTH</b>	44.5 in	113 cm
<b>HEIGHT (- cab)</b>	47.5 in	121 cm
<b>HEIGHT (+ cab)</b>	71 in	180 cm
<b>DECK HEIGHT</b>	28 in	71 cm
<b>WHEEL BASE</b>	50.5 in	128 cm
<b>BED SIZE</b>	44 x 63 in	112 x 160 cm

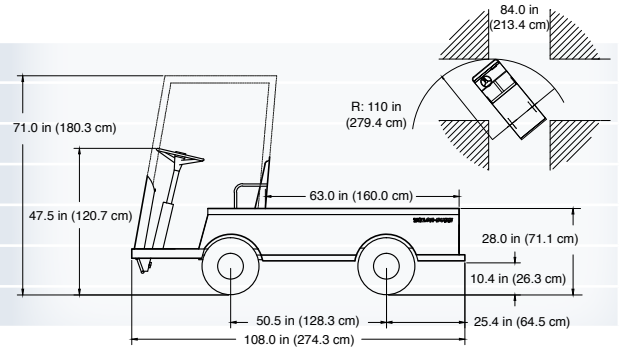

## POWER SUPPLY / DRIVE TRAIN

<b>MOTOR</b>	36V, DC, Series Wound, 6 Hp
<b>SYSTEM VOLTAGE</b>	36V DC
<b>DRIVE AXLE</b>	Direct Drive, Oil Bath, 14.78:1 Ratio, Transaxle Assembly, Sealed Helical Gear Reduction
<b>BATTERIES</b>	210 Amp-hour Lead Acid, 6 Volt, 6 Each
<b>CHARGER</b>	1 kW, Built-in, 36V, 110 VAC, 60Hz, w/ Interlock
<b>CONTROLLER</b>	275 amp, Solid State Speed Controller
<b>WIRING</b>	Modular Harness Design, Weather Protected Connectors

## CHASSIS

<b>FRAME</b>	Unitized Fully Welded 16 Gauge Diamond Plate Steel
<b>STEERING</b>	24:1 Ratio, Automotive
<b>SUSPENSION</b>	Leaf Springs, Front and Rear
<b>BRAKES</b>	Rear Mechanical Drum w/ Hand Operated Parking Brake
<b>BUMPERS</b>	Heavy Duty Steel Integrated Front
<b>TIRES</b>	5.70 x 8 Load Range C Pneumatic

## GENERAL

<b>UNIT WEIGHT</b>	1214 lb	550 kg
<b>SEATS</b>	Split Seat Bottom Cushion w/ Full Length Back Rest in Black Vinyl, 2 Person Capacity	
<b>INSTRUMENTATION</b>	Battery Status Indicator, Forward/Reverse Selector, Key Switch, Electric Horn	
<b>LIGHT ACCESSORIES</b>	Brake Lights	
<b>CONFORMANCE</b>	Type E OSHA 1910.178, ANSI B56.8	

## OPTIONS

- HYDRAULIC DRUM BRAKES
- SMOOTH SKIN BODY
- WINDSHIELD WIPER
- FIBERGLASS CAB
- VINYL DOORS
- FIBERGLASS TOP
- DIRECTIONAL SIGNALS
- PORTABLE CHARGER
- DUAL HEADLIGHTS
- STROBE LIGHT
- LADDER RACK
- STAKE SIDES
- BATTERY WATERING SYSTEM
- HOUR METER
- REVERSE ALARM
- VARIOUS HITCHES
- UNDERCOATING / GALVANIZING
- OPTIONAL COATING COLORS



2-YEAR  
2,000 HOUR



MANUFACTURERS  
WARRANTY

\*Specifications, standard equipment, accessories and modifications are all subject to change without notice.